

3 Assembling the safety edge

3.1 Types of mounting for the safety edge

Standard

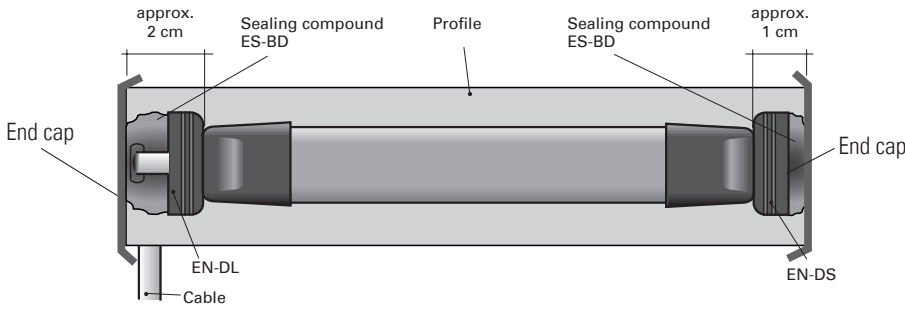

NB: End cap only if rubber profile is sealed

Note:

For S-Line use ENS-parts instead of EN-parts

Option for vertical applications (sliding gates) only

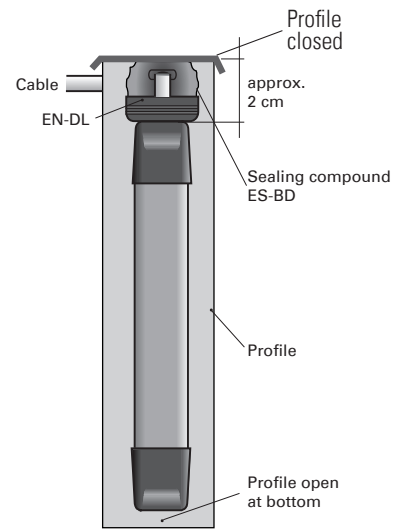

3.2 Sealing the switching chambers in the rubber profile

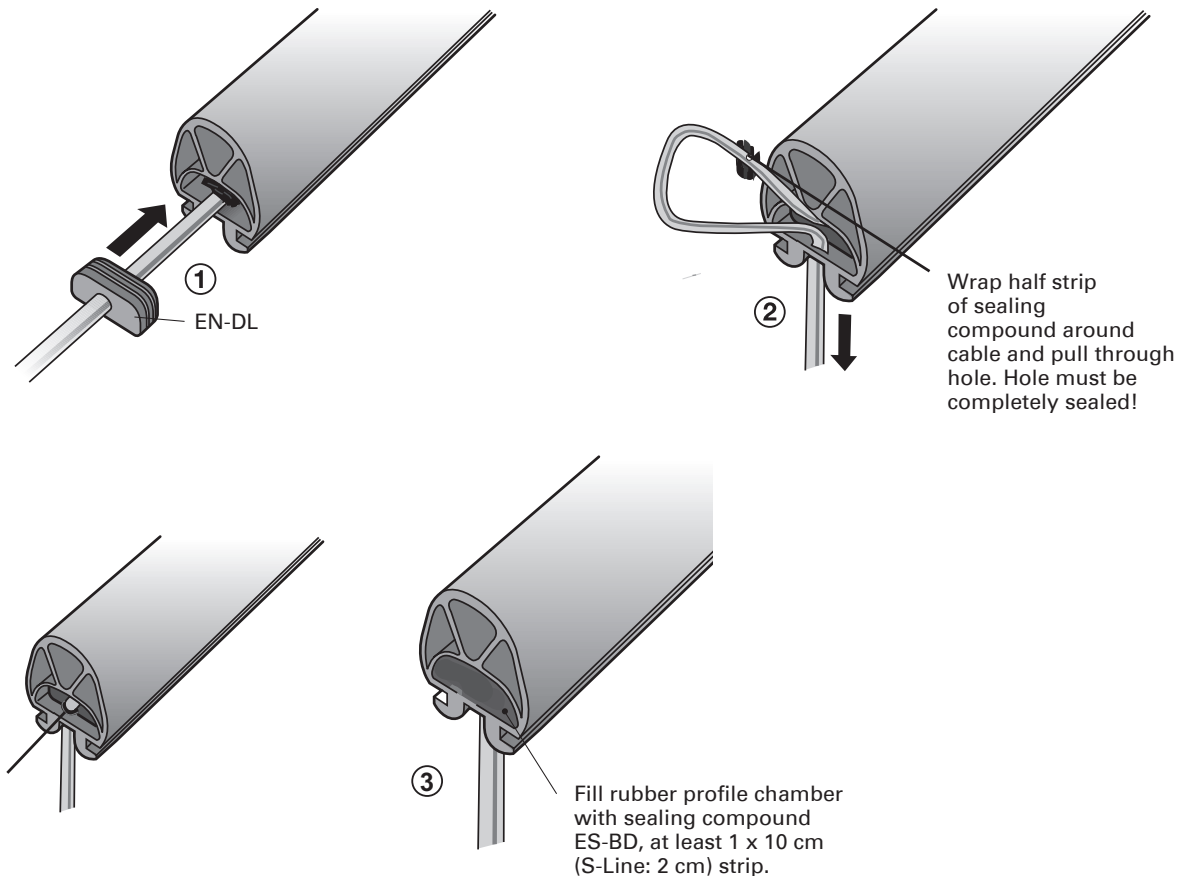

- ① Slide sealing plug EN-DL over cable, inserting at least 4 mm into the profile. Sealing plug EN-DS without hole on the side without a cable.
- ② Wrap ES-BD sealing compound around cable and pull through hole made with punch pliers using long-nosed pliers. The hole must be completely sealed with the compound.
- ③ Then fill the rest of the switching chamber with sealing compound and press down well.

Note: For ELE040/081 and ELE040/105: apply EN-KAS

3.3 Glueing on the end caps

ES-KLEBER

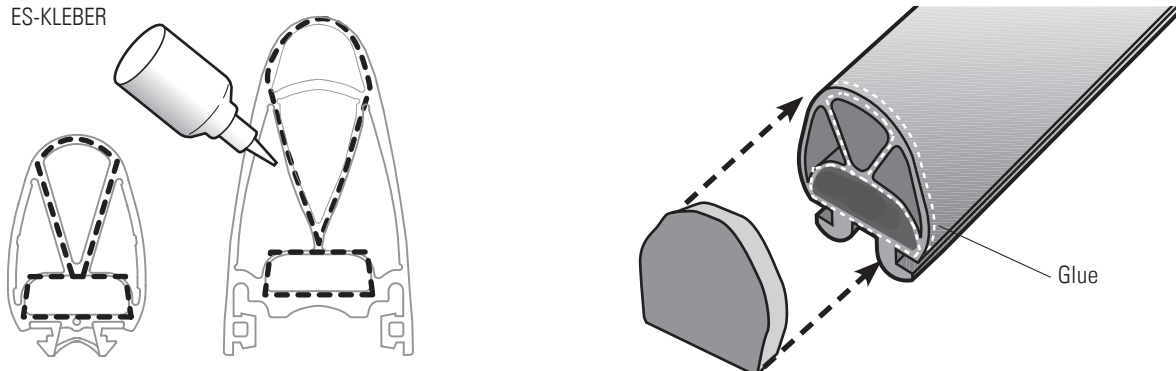

Attach end caps by applying ES-KLEBER to the points shown and hold in place, applying pressure across the whole area, for approx. 10 seconds.

Note: No end caps on ELE040/081 and ELE040/105

4 Mounting the safety edge

4.1 Attaching aluminium strip

Attach aluminium strip to object with **countersunk head screws**. Recommended hole spacing 300 mm. Make sure aluminium strip is securely attached to ends of safety edge. You may have to make holes for the cable to exit.

NB: In the case of 2-panel systems, the two profiles should be aligned facing each other. The same applies to any counter sealing profile.

Notice: If possible, avoid routing the cable through the aluminium profile as it may press against the switching chamber.

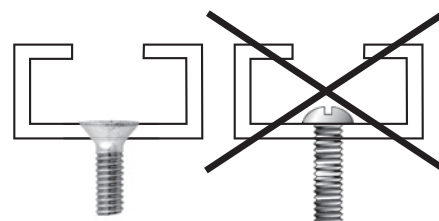

4.2 Mounting the rubber profile

- ① Press in profile at both ends
- ② Work from outside inwards

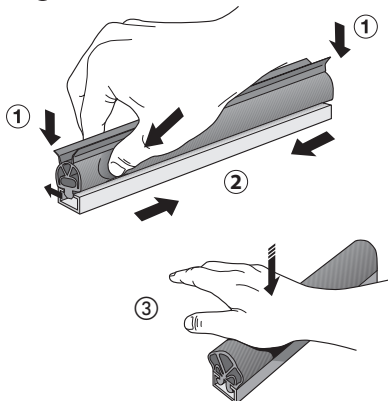

Moisten «click-fit foot» rubber profiles with a solution of soapy water and press into the aluminium profile (do not pull in).

T-foot rubber profiles should be pulled into the aluminium. Any burrs on the aluminium profile must be removed first.

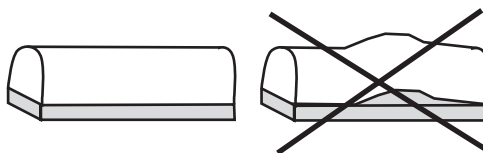

- ③ **To ensure correct functioning of safety edges with a click-fit foot, after mounting, the safety edge must be pressed in along its entire length to make sure the foot engages properly in the aluminium bar. Otherwise, the safety edge will connect through.** Check fit of rubber profile in aluminium strip.

4.3 Final checks

Warning: Perform a final functional and visual check of the safety edge. Once mounting is complete, test the safety edge on the object to make sure it functions correctly. The protection system must also satisfy the force, overtravel and sensitivity requirements of the standards applicable in the relevant country.

Check the resistance of the safety edge with an ohmmeter.

Notice: The overall safety of the machine and its protection systems depends on the quality, reliability and correct connection of the interfaces.

	End pieces		
	ENEH-8 ENES-8	ENEH-0 ENES-0	ENEH-K... ENES-K...
	8.1 - 8.5 kΩ	∞	∞
	< 500 Ω	< 500 Ω	< 500 Ω

5 Maintenance

The safety edge is maintenance-free. If damage occurs, such as a brittle or torn rubber profile, non-tight switching chamber, **insufficient contact resistance in the activated state (>500 ohms)** or similar, the safety edge must be replaced immediately. Please request a new one, remembering to state the product designation.

Check the resistance of the safety edge with an ohmmeter, referring to the table above.

6 Contact details

Manufacturer

Bircher Reglomat AG
Wiesengasse 20
CH-8222 Beringen
www.bircher-reglomat.com

Danish seller

Swissdoor ApS
Stenhuggervej 2
DK-5471 Soendersoe
mail@swissdoor.dk
www.swissdoor.dk